



Cable drag chain systems

MP 32

MP 32

OPEN

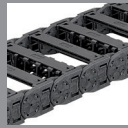

- PLASTIC OR ALUMINIUM VERSION
- FLEXIBLE CHAIN BRACKET
- BROAD INTERIOR LAYOUT

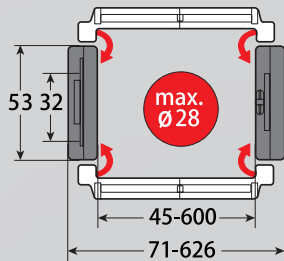

TECHNICAL DATA

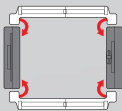

Loading side
Inside and outside bend

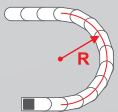

Available radii
80.0 – 250.0 mm

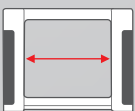

Available interior widths
With plastic frame bridge
45.0 – 546.0 mm
With Alu frame bridge / With Alu cover
67.0 – 600.0 mm /

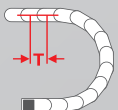

Pitch
T = 64.5 mm

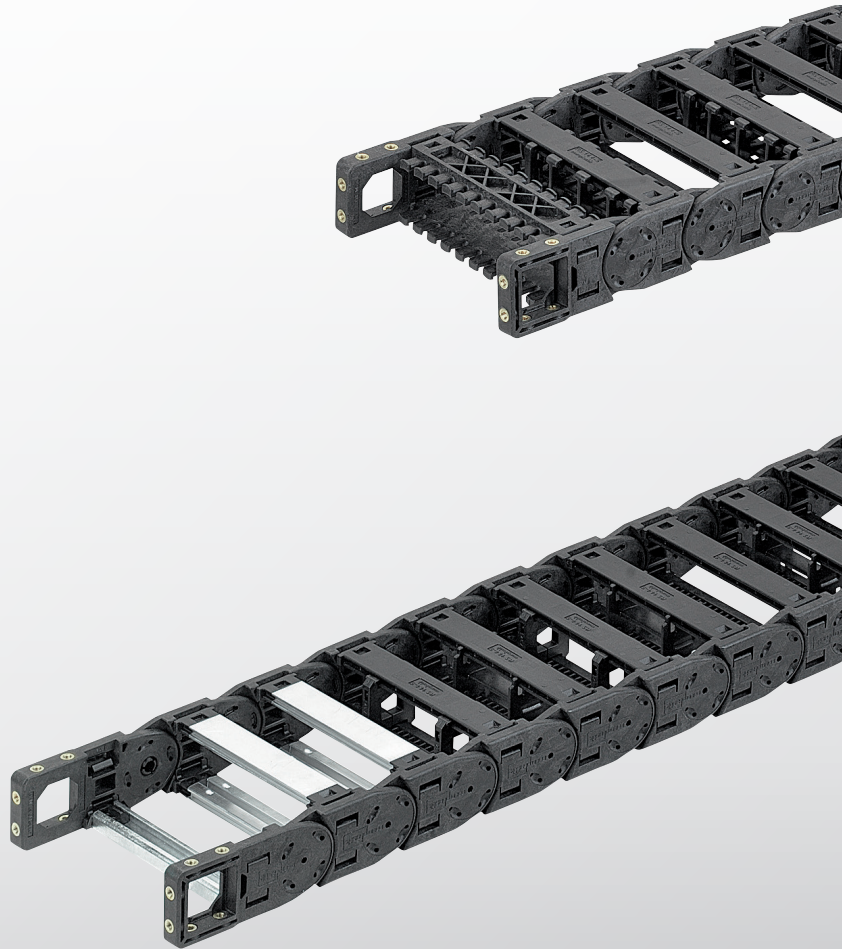



TECHNICAL SPECIFICATIONS

Travel distance gliding L_g max.	100.0 m
Travel distance self-supporting L_f max.	see diagram on page 5
Travel distance vertical, hanging L_{vh} max.	40.0 m
Travel distance vertical, upright L_{vs} max.	5.0 m
Rotated 90°, unsupported L_{90f} max.	2.0 m
Speed, gliding V_g max.	5.0 m/s
Speed, self-supporting V_f max.	20.0 m/s
Acceleration, gliding a_g max.	25.0 m/s ²
Acceleration, self-supporting a_f max.	30.0 m/s ²

Contact our engineering department to meet any higher requirements: efk@murrplastik.de

MATERIAL PROPERTIES

Standard material	Polyamide (PA) black
Service temperature	-30.0 – 120.0 °C
Gliding friction factor	0.3
Static friction factor	0.45
Fire classification	UL 94 HB

Other material properties on request.

SHELVING SYSTEM

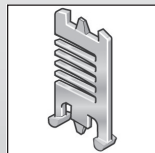

Separator TR

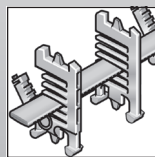

Shelving system RS

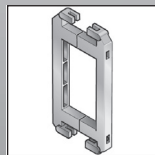

Frame bridge connector RSV

CHAIN BRACKET

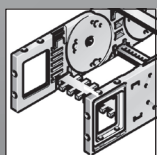

Chain bracket flexible

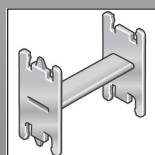

H-shaped shelf unit RE

ACCESSORIES

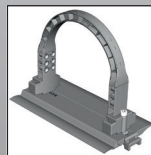

Extender frame bridge

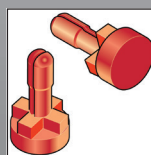

Lock button

GUIDE CHANNELS

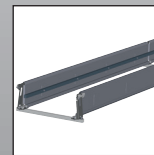

VAW steel galvanized / stainless steel

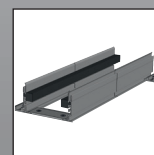

VAW aluminium

STRAIN RELIEF

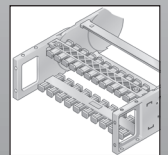

RS-ZL frame rail

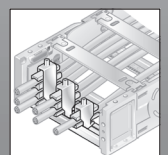

STF Steel Fix

ORDERING KEY

Dimensions in mm [US inch]

Type code	Variation	Inside width	Outside width	Inside width	Outside width	Radius	Rail variant	Material	Chain length
0320 30	Frame bridge on outside of radius Frame bridge on inside bend Opens on inside and outside of radius	045 [1.77]	071 [2.80]	233 [9.17]	259 [10.20]	080 [3.15]	0 Plastic, full-ridged with bias	0 Polyamide standard (PA/black)	
		057 [2.24]	083 [3.27]	246 [9.69]	272 [10.71]				
		062 [2.44]	088 [3.46]	252 [9.92]	278 [10.94]	100 [3.94]	2 Plastic, half-ridged with bias	9 Special version (on request)	
		071 [2.80]	097 [3.82]	258 [10.16]	284 [11.18]				
		084 [3.31]	110 [4.33]	296 [11.65]	322 [12.68]	120 [4.72]	4 Aluminium full-ridged with bias		
		093 [3.66]	119 [4.69]	346 [13.62]	372 [14.65]				
		096 [3.78]	122 [4.80]	350 [13.78]	376 [14.80]	150 [5.91]	6 Aluminium half-ridged with bias		
		104 [4.09]	130 [5.12]	358 [14.09]	384 [15.12]				
		107 [4.21]	133 [5.24]	371 [14.61]	397 [15.63]	200 [7.87]	9 Special version (on request)		
		121 [4.76]	147 [5.79]	396 [15.59]	422 [16.61]				
		133 [5.24]	159 [6.26]	421 [16.57]	447 [17.60]	250 [9.84]			
		144 [5.67]	170 [6.69]	446 [17.56]	472 [18.58]				
		146 [5.75]	172 [6.77]	496 [19.53]	522 [20.55]				
		158 [6.22]	184 [7.24]	546 [21.50]	572 [22.52]				
		164 [6.46]	190 [7.48]						
		171 [6.73]	197 [7.76]						
		182 [7.17]	208 [8.19]						
		196 [7.72]	222 [8.74]						
		208 [8.19]	234 [9.21]						
		220 [8.66]	246 [9.69]						

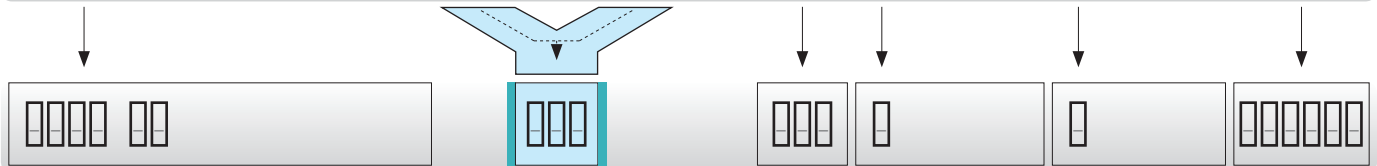

ORDER SAMPLE: 0320 30 045 080 0 0 1290

Frame bridge in outside bend, frame bridge in inside bend, can be opened from inside and outside bend
 Inside width 45 mm; radius 80 mm
 Plastic bridge, full-ridged with bias, material black-coloured polyamide
 Chain length 1290 mm (20 links)

NOTE ON CONFIGURATION

Aluminium frame bridges:

Aluminium frame bridges can be supplied in 1 mm width sizes for inner widths from 67.0 mm – 600.0 mm .

Crossbar connector and frame bridge strain relief plate:

Once inner widths exceed 246 mm, we recommend the deployment of crossbar connectors (RSV).
If frame bridge strain relief plates (RS-ZL) are to be deployed in the chain brackets, take standard inside widths into account.

product documentation.

For detailed information, please consult the corresponding

SELF-SUPPORTING LENGTH

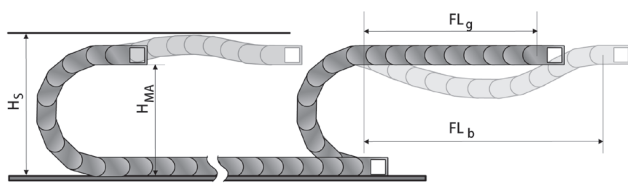

The self-supporting length is the distance between the chain bracket on the moving end and the start of the chain arch. The installation variant FL_g offers the lowest load and wear for the energy chain. The maximum travel parameters (speed and acceleration) can be applied for this variant.

- H_s = Installation height plus safety
- H_{MA} = Height of moving end connection
- FL_g = Self-supporting length, upper run straight
- FL_b = Self-supporting length, upper run bent

LOAD DIAGRAM FOR SELF-SUPPORTING APPLICATIONS

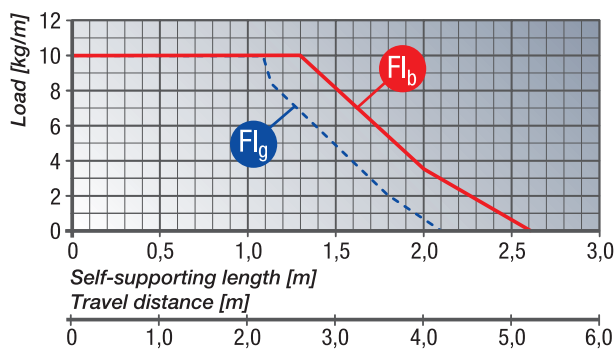

FL_g Self-supporting length, upper run straight
In the FL_g range, the chain upper run still has a bias, is straight or has a maximum sag of 70.0 mm.

FL_b Self-supporting length, upper run bent
In the FL_b range, the chain upper run has a sag of more than 70.0 mm, but this is still less than the maximum sag. Where the sag is greater than that permitted in the FL_b range, the application is critical and should be avoided. The self-supporting length can be optimized by using a support for the upper run or a more stable energy chain.

DETERMINING THE CHAIN LENGTH

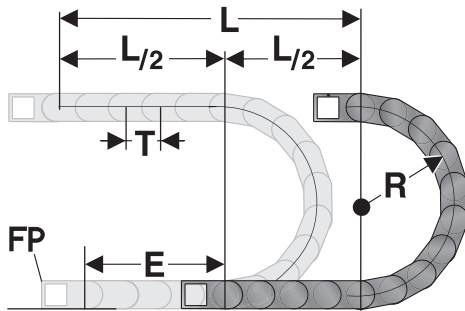

The fixed point of the energy chain should be connected in the middle of the travel distance.

This arrangement gives the shortest connection between the fixed point (FP) and the moving consumer and thus the most efficient chain length.

Chain length calculation = $L/2 + \pi * R + E$
 $\approx 1 \text{ m chain} = 16 \text{ qty. } \times 64.5 \text{ mm.}$

E = distance between entry point and middle of travel distance

L = travel distance

R = radius

P = Pitch 64.5 mm

EINBAUMASSE

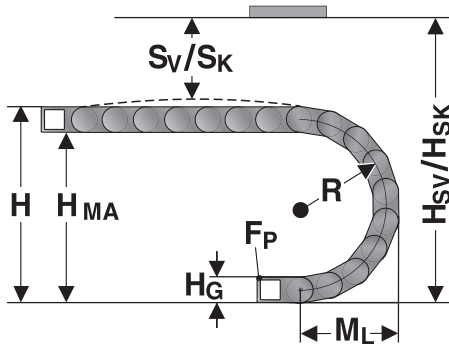

The moving end chain connection is to be screw fixed at height H_{MA} for the respective radius.

For the installed dimension the "Installed height H_s " value has to be taken into account.

Radius R	80	100	120	150	200	250
Outside height of chain link (H_o)	53	53	53	53	53	53
Height of bend (H)	233	273	313	373	473	573
Height of moving end bracket (H_{MA})	180	220	260	320	420	520
Safety margin (S)	30	30	30	30	30	30
Installation height (H_s)	263	303	343	403	503	603
Arc projection (M_l)	181	201	221	251	301	351

POWERLINE PLASTIC FRAME BRIDGE



Frame bridge

The frame bridges connect the two side runs of the energy chain. The frame bridge length is synonymous with the inside width of the energy chain.

Type	Order No.	Designation	Inside width mm
RS 045-5	052004500000	Frame bridge	45.0
RS 057-5	052005700000	Frame bridge	57.0
RS 062-5	052006200000	Frame bridge	62.0
RS 071-5	052007100000	Frame bridge	71.0
RS 084-5	052008400000	Frame bridge	84.0
RS 093-5	052009300000	Frame bridge	93.0
RS 096-5	052009600000	Frame bridge	96.0
RS 104-5	052010400000	Frame bridge	104.0
RS 107-5	052010700000	Frame bridge	107.0
RS 121-5	052012100000	Frame bridge	121.0
RS 133-5	052013300000	Frame bridge	133.0
RS 144-5	052014400000	Frame bridge	144.0
RS 146-5	052014600000	Frame bridge	146.0
RS 158-5	052015800000	Frame bridge	158.0
RS 164-5	052016400000	Frame bridge	164.0
RS 171-5	052017100000	Frame bridge	171.0
RS 182-5	052018200000	Frame bridge	182.0
RS 196-5	052019600000	Frame bridge	196.0
RS 208-5	052020800000	Frame bridge	208.0
RS 220-5	052022000000	Frame bridge	220.0
RS 233-5	052023300000	Frame bridge	233.0
RS 246-5	052024600000	Frame bridge	246.0
RS 252-5	052025200010	Frame bridge	252.0
RS 258-5	052025800000	Frame bridge	258.0
RS 296-5	052029600000	Frame bridge	296.0
RS 346-5	052034600000	Frame bridge	346.0
RS 350-5	052035000000	Frame bridge	350.0
RS 358-5	052035800000	Frame bridge	358.0
RS 371-5	052037100000	Frame bridge	371.0
RS 396-5	052039600000	Frame bridge	396.0
RS 421-5	052042100000	Frame bridge	421.0
RS 446-5	052044600000	Frame bridge	446.0
RS 496-5	052049600000	Frame bridge	496.0
RS 546-5	052054600000	Frame bridge	546.0

KA 32 FLEXIBLE CHAIN BRACKET

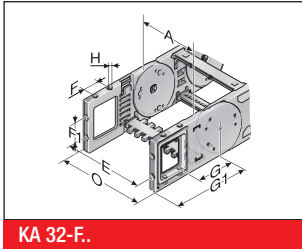

This chain bracket offers universal connection options (top, bottom and front) and is attached to the ends of the chain like a side link. This allows the chain to move right up to the bracket. Each chain requires one male and one female bracket. M5 screws are used to secure the brackets in place. Extrusion-coated metal bushes with either a through-hole (-FB) or a threaded hole (-FG) ensure the permanent, high-strength transmission of even extreme forces onto the cable drag chain.

Type	Order No.	Material	Version	Inside width							Outside width KA	
				A mm	E mm	F mm	F1 mm	G mm	G1 mm	H mm	H0 mm	O mm
KA 32-FB	0321000054	Plastic	with bush	45.0 – 546.0	A+14.0	22.5	22.0	57.8	95.5	95.5	5.5	A+28.0
KA 32-FG	0321000055	Plastic	with thread	45.0 – 546.0	A+14.0	22.5	22.0	57.8	95.5	M5		A+28.0

SEPARATOR TR 32

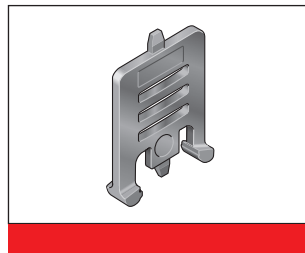
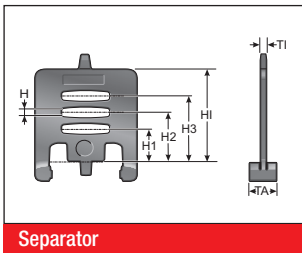

We recommend that separators be used if multiple round cables or conduits with differing diameters are to be installed.

Type	Order No.	Designation	Version	T1 mm	TA mm	H mm	H1 mm	H2 mm	H3 mm	H4 mm
TR 32	032000009200	Separator	lockable	3.0	10.0	4.2	10.4	16.2	22.0	32.0

SEPARATOR TR 32.1

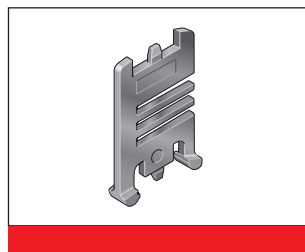
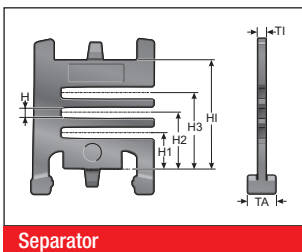

We recommend that separators be used if multiple round cables or conduits with differing diameters are to be installed.

Type	Order No.	Designation	Version	T1 mm	TA mm	H mm	H1 mm	H2 mm	H3 mm	H4 mm
TR 32.1	032200009200	Separator	lockable	3.5	8.0	4.0	10.5	16.5	22.5	32.0

RTT 32 SHELF SUPPORT, DIVISIBLE

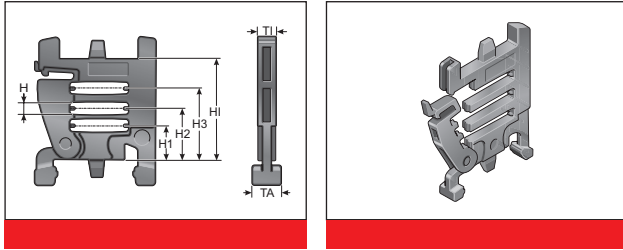

In connection with two separable shelf supports (RTT) with at least one end-to-end shelf (RB) the shelf becomes an easy to fill shelving system. The additional levels prevent cables from criss-crossing and minimise the friction between them.

Type	Order No.	Designation	Version	TI mm	TA mm	H mm	H1 mm	H2 mm	H3 mm	H6	H7	H8 mm
RTT 32	100090322000	Shelf support, divisible	lockable	7.0	8.0	4.0	10.5	16.5	22.5			32.0

RB-5 SHELF

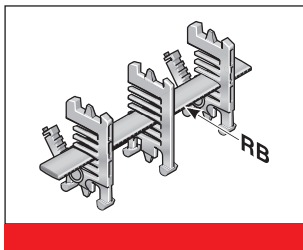

In connection with at least two separable shelf supports (RTT), the shelf becomes a shelving system. The additional levels prevent cables from criss-crossing and minimise the friction between them.

Type	Order No.	Designation	Width mm	für Innenbreite mm
RB 028-5	10000002800	Shelf	28.0	45.0
RB 034-5	1000003405	Shelf	33.6	45.0
RB 039-5	1000003905	Shelf	39.2	45.0
RB 045-5	1000004505	Shelf	44.8	57.0
RB 050-5	1000005005	Shelf	50.4	57.0
RB 056-5	10000005601	Shelf	56.0	62.0
RB 062-5	1000006205	Shelf	61.6	62.0
RB 067-5	1000006705	Shelf	67.2	84.0
RB 073-5	1000007305	Shelf	72.8	84.0
RB 078-5	1000007805	Shelf	78.4	84.0
RB 084-5	10000008400	Shelf	84.0	84.0
RB 090-5	1000009005	Shelf	89.6	96.0
RB 095-5	1000009505	Shelf	95.2	96.0
RB 101-5	1000010105	Shelf	100.8	107.0
RB 106-5	1000010605	Shelf	106.4	107.0
RB 112-5	100000011200	Shelf	112.0	121.0
RB 118-5	1000011805	Shelf	117.6	121.0
RB 123-5	1000012305	Shelf	123.2	133.0
RB 129-5	1000012905	Shelf	128.8	133.0
RB 134-5	1000013405	Shelf	134.4	144.0
RB 140-5	100000014000	Shelf	140.0	144.0
RB 146-5	1000014605	Shelf	145.6	158.0

RB-5 SHELF

Type	Order No.	Designation	Width mm	für Innenbreite mm
RB 151-5	1000015105	Shelf	151.2	158.0
RB 157-5	1000015705	Shelf	156.8	164.0
RB 162-5	1000016205	Shelf	162.4	164.0
RB 168-5	100000016800	Shelf	168.0	182.0
RB 174-5	1000017405	Shelf	173.6	182.0
RB 179-5	1000017905	Shelf	179.2	196.0
RB 185-5	1000018505	Shelf	184.8	196.0
RB 190-5	1000019005	Shelf	190.4	196.0
RB 196-5	100000019600	Shelf	196.0	196.0
RB 291-5	100000029100	Shelf	291.2	346.0

CROSSBAR CONNECTOR RSV 32

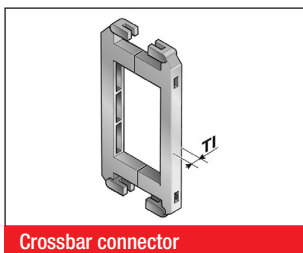

Crossbar connector

For frame bridges wider than 246 mm, we recommend the use of crossbar connectors. These prevent deformation to the frame bridge under large amounts of additional weight of the chain assembly.

Type	Order No.	Designation	T1 mm
RSV 32	032000009600	Crossbar connector	7.5
RSV 32 Alu	032000009800	Crossbar connector for aluminium frame bridges	7.5

RE 32 H-SHAPED SHELF UNIT

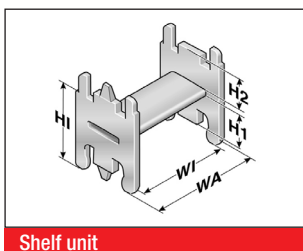

Shelf unit

One-piece shelving system, the shelf cannot be varied in height.

Type	Order No.	Designation	WA mm	WI mm	H1 mm	H2 mm	HI mm
RE 32/35	100000322010	H-shaped shelf unit	43.2	35.2	14.2	14.2	32.4
RE 32/52	100000323510	H-shaped shelf unit	60.0	52.0	14.2	14.2	32.4
RE 32/75	100000327510	H-shaped shelf unit	82.4	74.4	16.4	12.0	32.4

BS -5 BRACKET BAR

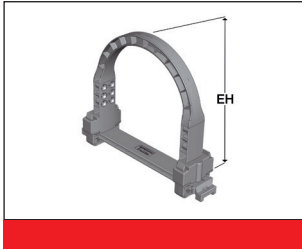

Large-diameter conduits are routed securely by using a bracket bar (BS). Installation is done on the frame bridges or the covers of the energy chain.

The bracket bar can be installed on both the inside and outside bend.

The bracket bar support (BSH) is used to attach the bars to PowerLine series frame bridges. Two bracket bar supports are required for each bar.

RS-ZL-5 FRAME RAIL TENSION RELIEF

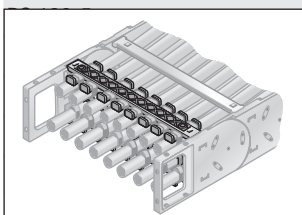

Frame bridge strain relief plate

Order No.	Description	Fixed integrated frame bridge	Frame bridge width	Frame bridge height	Chain width min. mm
052412000000	Extender frame bridge	115.0	140.0	164.0	164.0
052415300000	Extender frame bridge	140.0	165.0	188.0	188.0
052418700000	Extender frame bridge	165.0	190.0	213.0	213.0
052400000000	Extender frame bridge holder	182.0	205.0	233.0	233.0
RS-5/RS-7 052400000001	Assembly set bracket bar				

Type	Order No.	Designation	für Innenbreite mm
RS-ZL 045-5	052004500010	Frame bridge strain relief plate	45.0
RS-ZL 057-5	052005700010	Frame bridge strain relief plate	57.0
RS-ZL 062-5	052006200010	Frame bridge strain relief plate	62.0
RS-ZL 071-5	052007100010	Frame bridge strain relief plate	71.0
RS-ZL 084-5	052008400010	Frame bridge strain relief plate	84.0
RS-ZL 093-5	052009300010	Frame bridge strain relief plate	93.0
RS-ZL 096-5	052009600010	Frame bridge strain relief plate	96.0
RS-ZL 104-5	052010400010	Frame bridge strain relief plate	104.0
RS-ZL 107-5	052010700010	Frame bridge strain relief plate	107.0
RS-ZL 121-5	052012100010	Frame bridge strain relief plate	121.0
RS-ZL 133-5	052013300010	Frame bridge strain relief plate	133.0
RS-ZL 144-5	052014400010	Frame bridge strain relief plate	144.0
RS-ZL 146-5	052014600010	Frame bridge strain relief plate	146.0
RS-ZL 158-5	052015800010	Frame bridge strain relief plate	158.0
RS-ZL 164-5	052016400010	Frame bridge strain relief plate	164.0
RS-ZL 171-5	052017100010	Frame bridge strain relief plate	171.0
RS-ZL 182-5	052018200010	Frame bridge strain relief plate	182.0
RS-ZL 196-5	052019600010	Frame bridge strain relief plate	196.0
RS-ZL 208-5	052020800010	Frame bridge strain relief plate	208.0
RS-ZL 220-5	052022000010	Frame bridge strain relief plate	220.0
RS-ZL 233-5	052023300010	Frame bridge strain relief plate	233.0
RS-ZL 246-5	052024600010	Frame bridge strain relief plate	246.0

STRAIN RELIEF WITH STEEL FIX

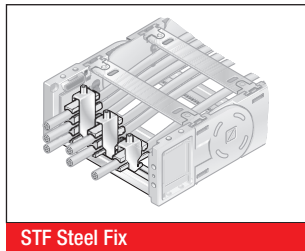
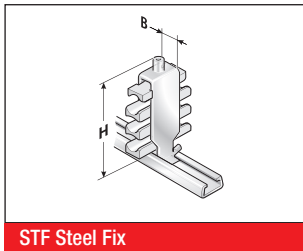

C-rails (galvanized) for permanent integration, for accommodating the Steel Fix bow clamps in the chain brackets. The bow clamps can take up to 3 cables and are suitable for C-rails with a groove width of 11 mm. Due to the design of the trough elements, a cable preserving cable guidance is ensured. May be assembled on the inside and outside bends at both chain endings. The overall height stated is a guide only. The actual height is, amongst other things, dependent on the diameter and the quality of the cable. A safety distance of 10 mm at the fixed point above the strain relief must be kept during gliding applications.

Type	Order No.	Designation	Seats qty.	Cable Ø mm	Overall height (H) mm
Single clamp (for two cables)					
STF 12-1 Steel Fix	81661801	Hooped clamp	1	6.0 – 12.0	55.0
STF 14-1 Steel Fix	81661802	Hooped clamp	1	12.0 – 14.0	52.0
STF 16-1 Steel Fix	81661803	Hooped clamp	1	14.0 – 16.0	54.0
STF 18-1 Steel Fix	81661804	Hooped clamp	1	16.0 – 18.0	56.0
STF 20-1 Steel Fix	81661805	Hooped clamp	1	18.0 – 20.0	59.0
STF 22-1 Steel Fix	81661806	Hooped clamp	1	20.0 – 22.0	61.0
STF 26-1 Steel Fix	81661807	Hooped clamp	1	22.0 – 26.0	70.0
STF 30-1 Steel Fix	81661808	Hooped clamp	1	26.0 – 30.0	74.0
STF 34-1 Steel Fix	81661809	Hooped clamp	1	30.0 – 34.0	78.0
STF 38-1 Steel Fix	81661810	Hooped clamp	1	34.0 – 38.0	82.0
STF 42-1 Steel Fix	81661811	Hooped clamp	1	38.0 – 42.0	91.0
Double clamp (for two cables)					
STF 12-2 Steel Fix	81661821	Hooped clamp	2	6.0 – 12.0	73.0
STF 14-2 Steel Fix	81661822	Hooped clamp	2	12.0 – 14.0	74.0
STF 16-2 Steel Fix	81661823	Hooped clamp	2	14.0 – 16.0	82.0
STF 18-2 Steel Fix	81661824	Hooped clamp	2	16.0 – 18.0	86.0
STF 20-2 Steel Fix	81661825	Hooped clamp	2	18.0 – 20.0	91.0
STF 22-2 Steel Fix	81661826	Hooped clamp	2	20.0 – 22.0	95.0
STF 26-2 Steel Fix	81661827	Hooped clamp	2	22.0 – 26.0	108.0
STF 30-2 Steel Fix	81661828	Hooped clamp	2	26.0 – 30.0	121.0
STF 34-2 Steel Fix	81661829	Hooped clamp	2	30.0 – 34.0	129.0
Triple clamp (for three cables)					
STF 12-3 Steel Fix	81661841	Hooped clamp	3	6.0 – 12.0	98.0
STF 14-3 Steel Fix	81661842	Hooped clamp	3	12.0 – 14.0	98.0
STF 16-3 Steel Fix	81661843	Hooped clamp	3	14.0 – 16.0	105.0
STF 18-3 Steel Fix	81661844	Hooped clamp	3	16.0 – 18.0	111.0
STF 20-3 Steel Fix	81661845	Hooped clamp	3	18.0 – 20.0	118.0
STF 22-3 Steel Fix	81661846	Hooped clamp	3	20.0 – 22.0	130.0

MP 32/41 LOCK BUTTON

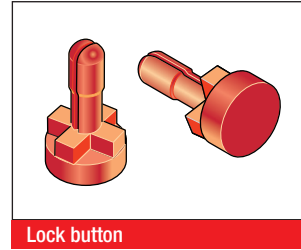
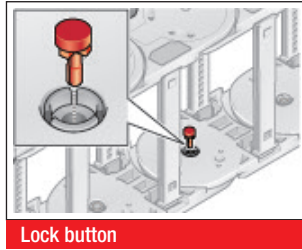
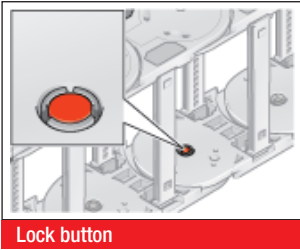

To increase the side stability, we recommend the use of lock buttons during strong lateral acceleration or when installed

“laying on the side (turned 90°) without support”.

Type	Order No.
MP32/41 lock button	04100008000

LOWERED FIXING POINT MP 32

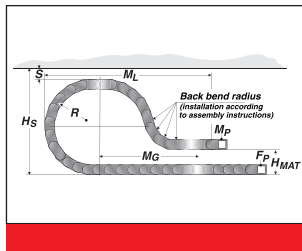
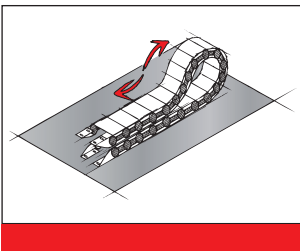

It is sometimes necessary to lower the height of the moving attachment point.

In such cases, modifications to the chain layout should be noted (e.g. extension of chain).

Please contact our application engineers.

Radius R mm	Height of moving end bracket (H _{MA}) mm	Safety margin (S) mm	Installation height incl. safety (H _S) mm	Projection (M _L) mm	Additional links qty.	of which additional back chain links qty.
200.0	210.0	50.0	523.0	720.0	14	3
250.0	230.0	50.0	623.0	880.0	17	3

REAR-FACING MP 32

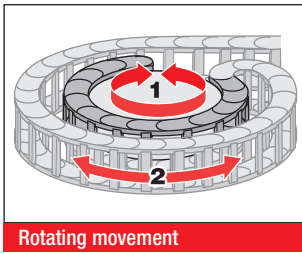

Side links with rearward radius allow movements in both directions. This is intended for rotating movements and lowered chain brackets. Rotation movements are only possible with open variants.

Type	Order No.	Radius mm	Rear-facing radius mm
SR 32 (RÜ200/R120)	032000008060	120.0	200.0
SR 32 (RÜ200/R135)	032000010060	135.0	200.0
SR 32 (RÜ200/R150)	032000012060	150.0	200.0
SR 32 (RÜ200/R170)	032000015060	170.0	200.0
SR 32 (RÜ200/R200)	032000020060	200.0	200.0
SR 32 (RÜ200/R250)	032000025060	250.0	200.0

GUIDE CHANNEL VAW (ALUMINIUM / STAINLESS STEEL)

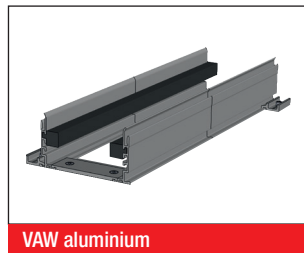

A range of variable guide channel systems, constructed from aluminium or stainless steel sections, are available for this energy chain. The variable guide channel ensures that the energy chain is supported and guided securely. For help on choosing, please consult the chapter “Variable Guide Channel System”.

ASSEMBLY INSTRUCTION FLEXIBLE CHAIN BRACKET FB/FG

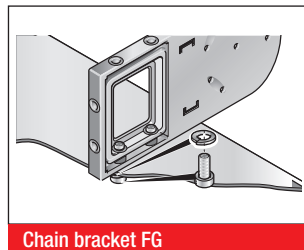
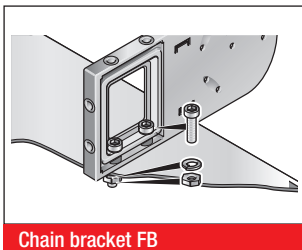

Brass bushes guarantee long-lasting fastening without cold flow in the plastic.

Version KA-FB:
Integrated through-hole fastened down using screw and nut.
Version KA-FG:
Built-in threads allow for quick and easy on-site mounting, since a screw, including a retaining washer where necessary, is sufficient.

ASSEMBLY

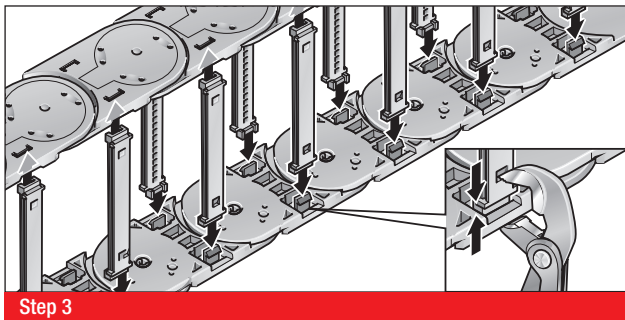
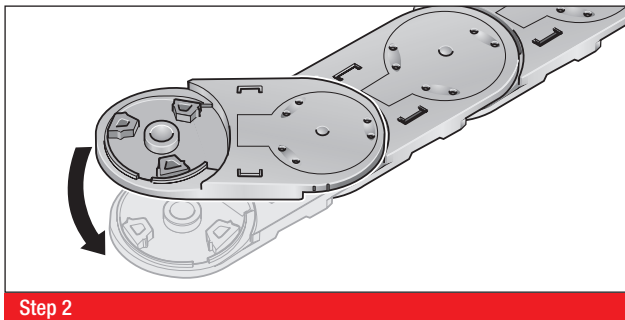
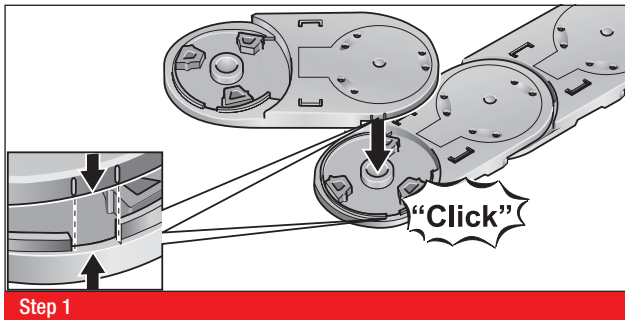

DISASSEMBLY

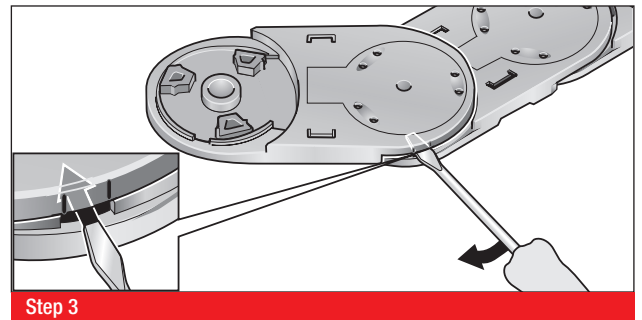
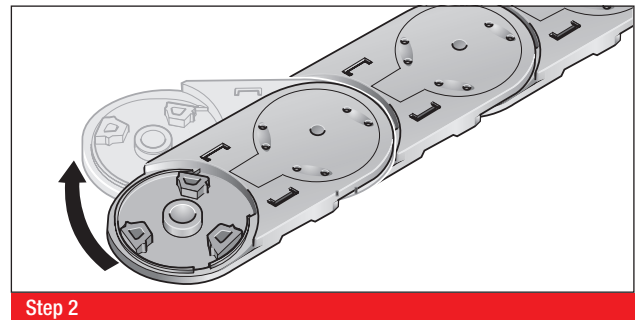
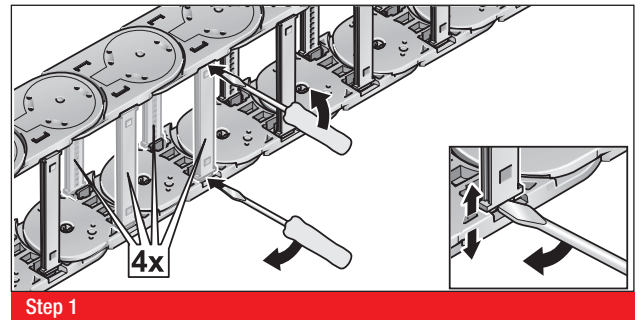

All details given in our sales material prospectuses and catalogues as well as the information available online are based on our current knowledge of the products described.

The electronic data and files made available by Murrplastik, particularly CAD files are based on our current knowledge of the product described.

A legally binding assurance of certain properties or the suitability for a certain purpose can not be determined from this information.

All information with respect to the chemical and physical properties of Murrplastik products as well as application advice given verbally, in writing or by tests, is given to the best of our knowledge.

This does not free the purchaser of carrying out their own inspections and tests in order to determine the suitability of a product for a specific purpose.

Murrplastik accepts no responsibility for the available information being up-to-date, correct or complete. Neither do we accept responsibility for the quality of this information.

Murrplastik accepts no liability for damage caused as a result of using our products.

Murrplastik reserves the right to make technical changes and improvements through constant further development of products and services.

Our General Terms and Conditions apply.